

# CITY OF SOMERVILLE

## OFFICE OF STRATEGIC PLANNING AND COMMUNITY DEVELOPMENT

### TRANSPORTATION AND INFRASTRUCTURE DIVISION

SIGNING AND PAVEMENT MARKING PLAN OF

## BROADWAY

(MEDFORD STREET TO MCGRATH HIGHWAY)

WARDS 4 & 5

# 100% SUBMITTAL

**SOMERVILLE  
CENTRAL BROADWAY**

STATE	FED. AID PROJ. NO.	SHEET NO.	TOTAL SHEETS
MA		1	13
PROJECT FILE NO. XXXXXX			

TITLE SHEET

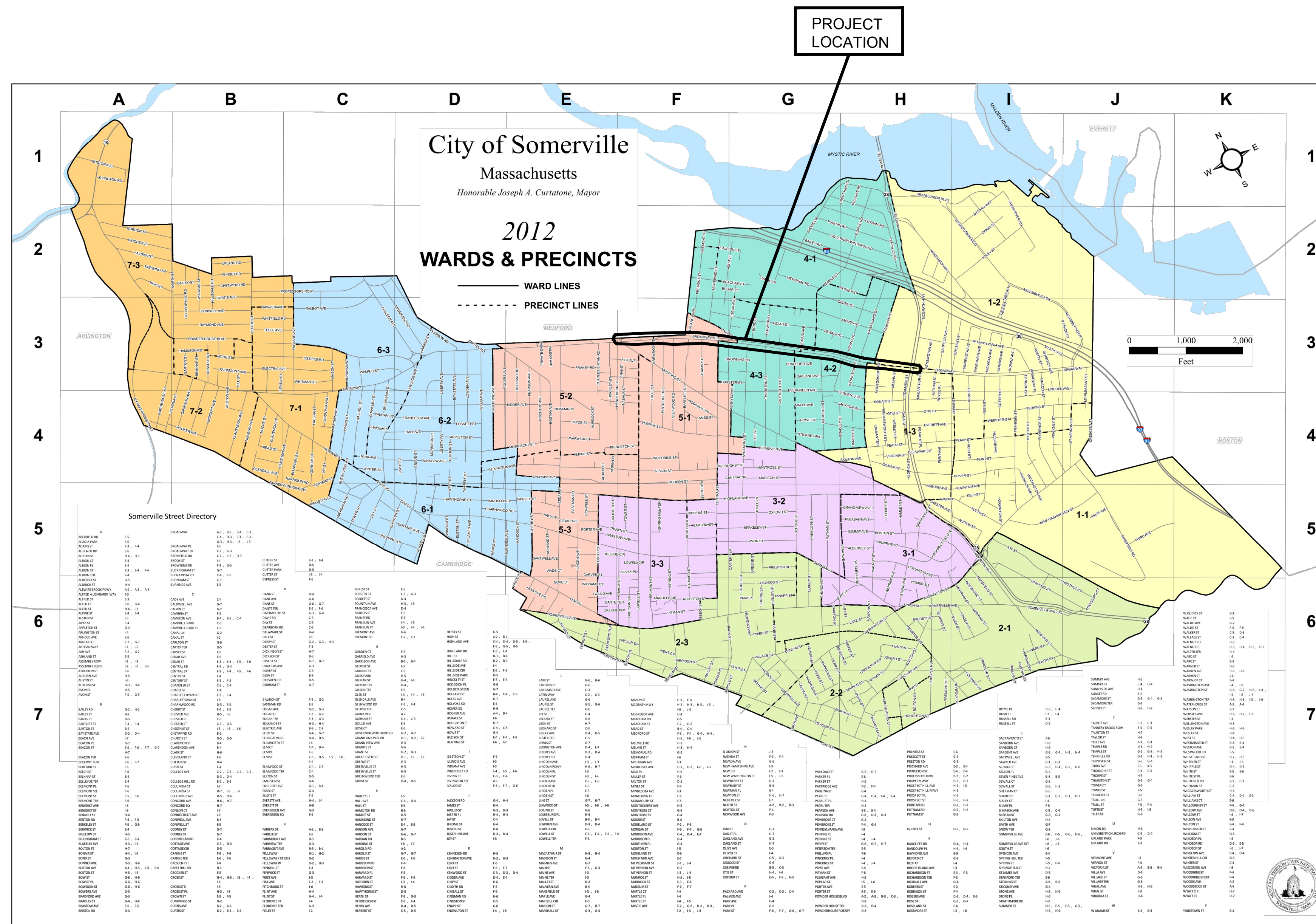

LENGTH OF PROJECT = 5150 FEET = 0.975 MILES

### INDEX

SHEET NO.	DESCRIPTION
1	TITLE SHEET & INDEX
2	NOTES & DETAILS SHEET
3-11	TRAFFIC SIGN & PAVEMENT MARKINGS
12-13	TRAFFIC SIGN SUMMARY SHEET

DATE	DESCRIPTION	REV #

**294 WASHINGTON ST SUITE 11**  
**BOSTON, MA 02108**  
[www.kittelston.com](http://www.kittelston.com)  
 617-377-4000

**SUBMITTED BY**

\_\_\_\_\_

**DATE**

\_\_\_\_\_

PREPARED BY JXD

CHECKED BY RIN

DATE 07/24/2019

**APPROVED BY**

\_\_\_\_\_

**CITY ENGINEER**

**DATE**

\_\_\_\_\_

**SOMERVILLE  
CENTRAL BROADWAY**

STATE	FED. AID PROJ. NO.	SHEET NO.	TOTAL SHEETS
MA		2	13
PROJECT FILE NO.		XXXXXX	

**NOTES & DETAILS SHEET**

**GENERAL NOTES**

- FOR FULL PROJECT LENGTH, ALL EXISTING SIGNS & SIGN POSTS ARE TO BE REMOVED & STACKED EXCEPT PRIVATE SIGNS UNLESS OTHERWISE NOTED, OR AS DIRECTED BY FIELD ENGINEER.
- ALL SIGNS SHALL CONFORM TO THE MANUAL ON UNIVERSAL TRAFFIC CONTROL DEVICES (MUTCD) 2009 EDITION WITH REVISIONS AND AS AMENDED BY THE MASSACHUSETTS DEPARTMENT OF TRANSPORTATION.
- THE MINIMUM SIGN MOUNTING HEIGHT, MEASURED VERTICALLY FROM THE BOTTOM OF THE LOWEST SIGN TO THE TOP OF THE CURB OR SIDEWALK SHALL BE 7 FEET UNLESS OTHERWISE SPECIFIED ON THE PLANS.
- WHEN MOUNTING NEW SIGNS & POSTS, CONTRACTOR SHALL NOT PLACE THEM WHERE THE VISIBILITY OF THE SIGN WILL BE OBSTRUCTED. THE SIGNS SHALL BE UNOBSTRUCTED TO ALL ROAD USERS. IF THE NEW SIGN POST IS IN CONFLICT WITH OTHER SURFACE STRUCTURES, THE PROBLEM SHALL BE REPORTED TO THE FIELD ENGINEER.
- ALL SIGNS MOUNTED ALONG THE SIDE STREETS SHALL REMAIN IN PLACE.
- IF NECESSARY, CONFLICTING EXISTING PAVEMENT MARKINGS SHALL BE REMOVED BY USING CITY APPROVED METHODS ONLY.

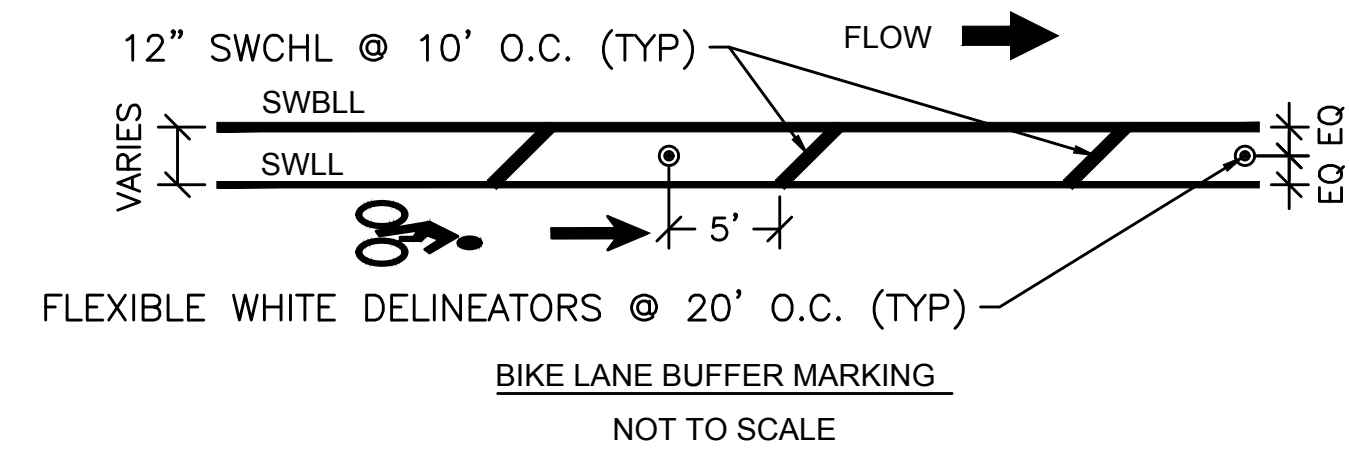
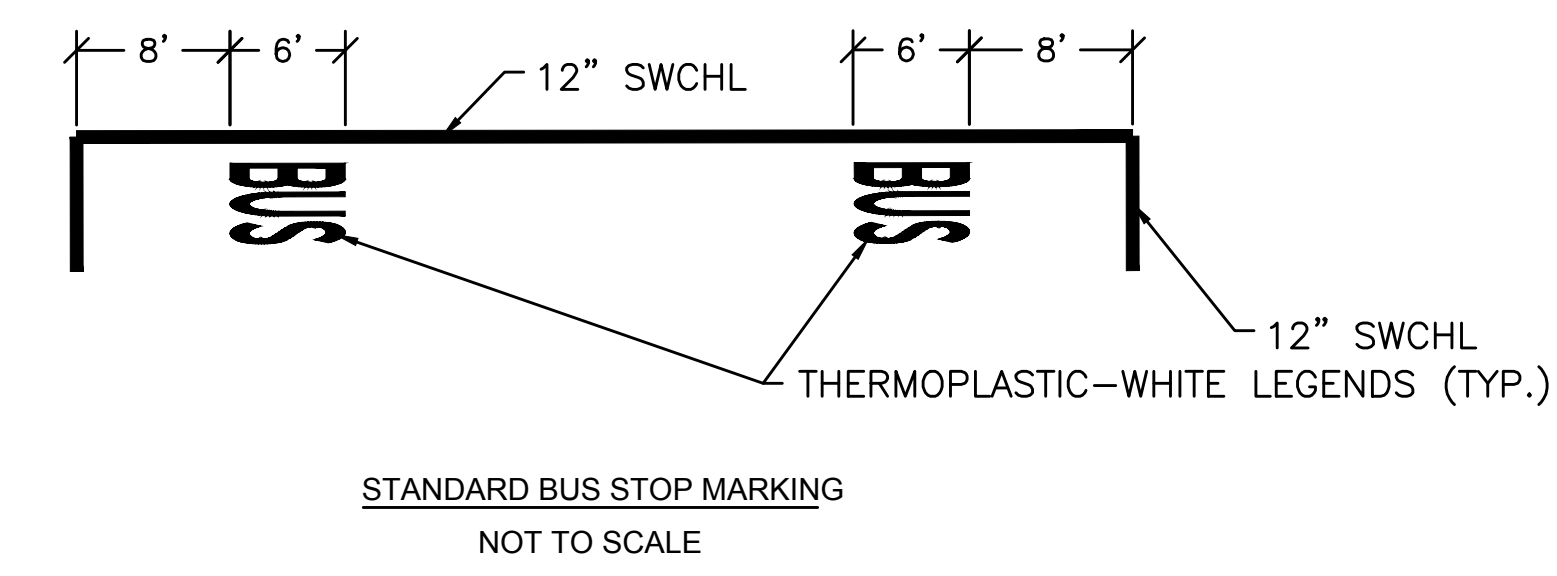
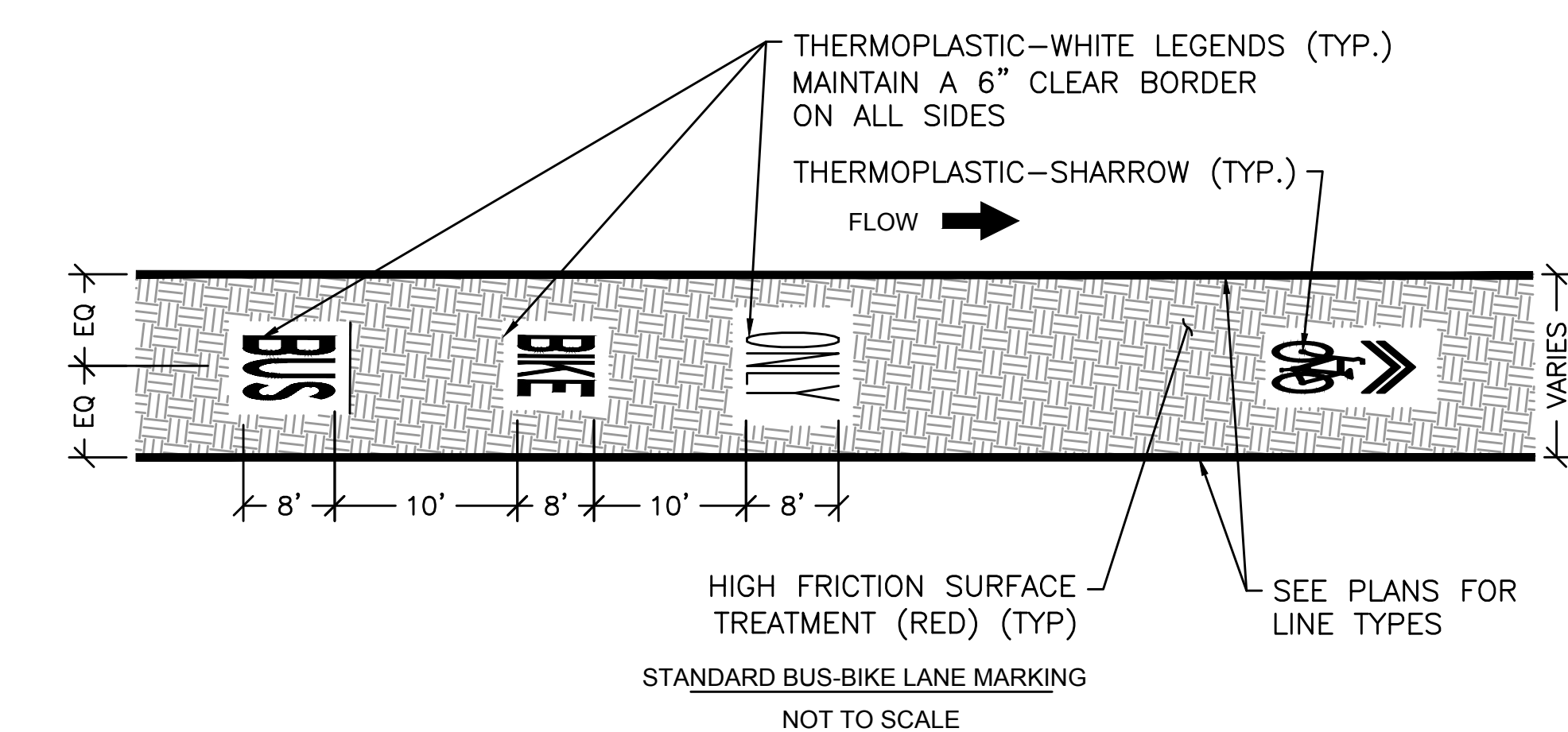
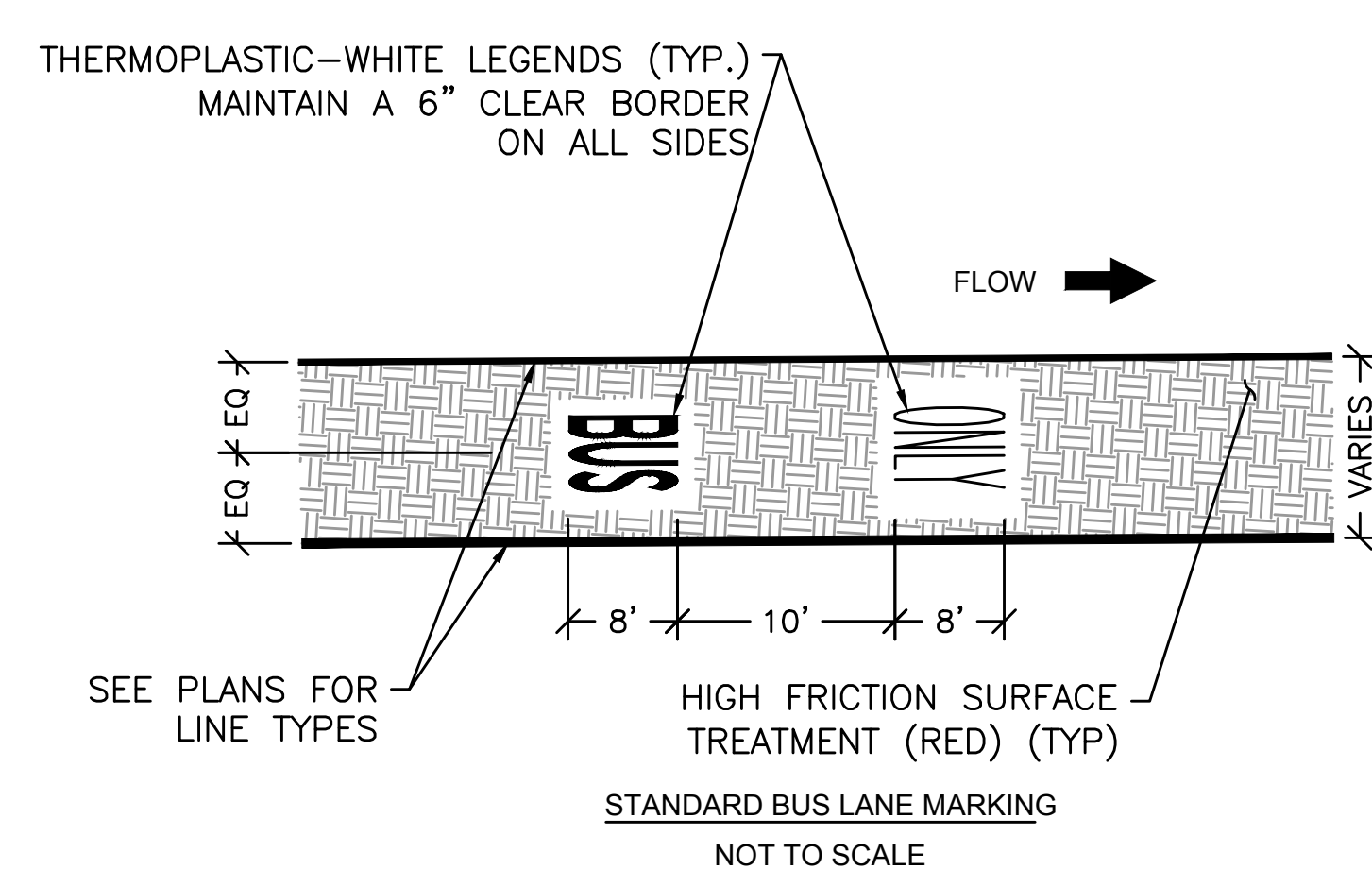
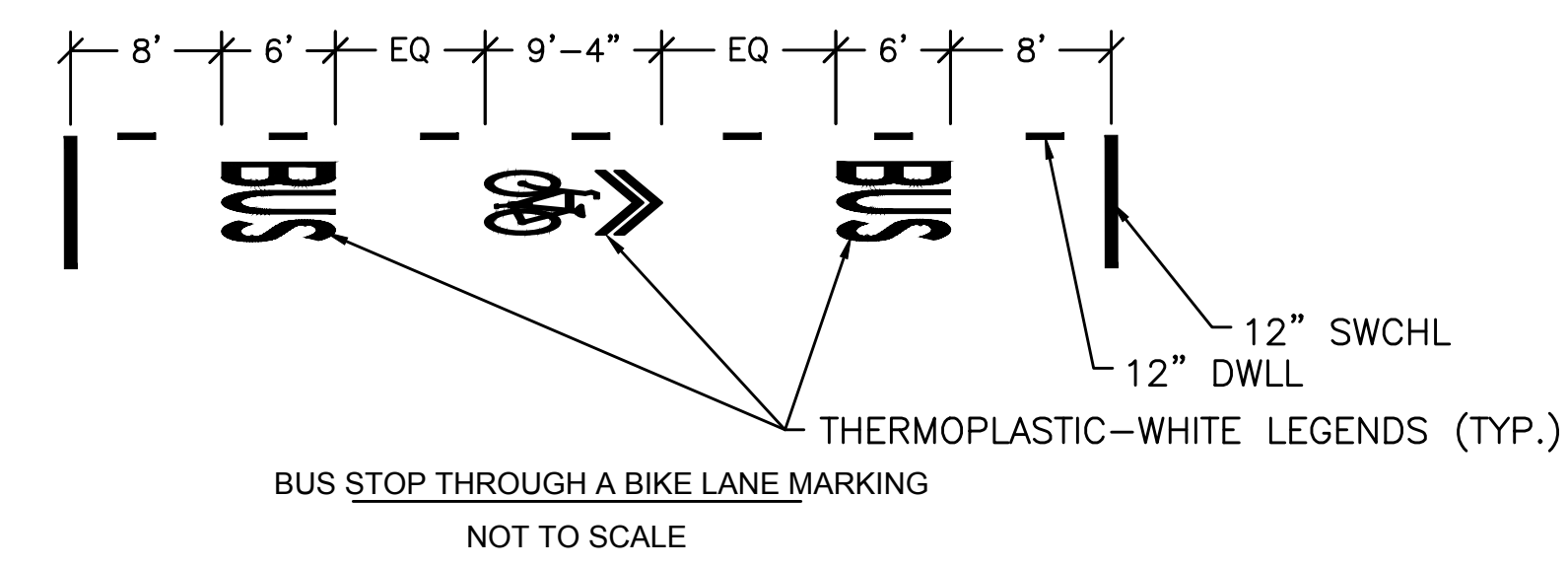
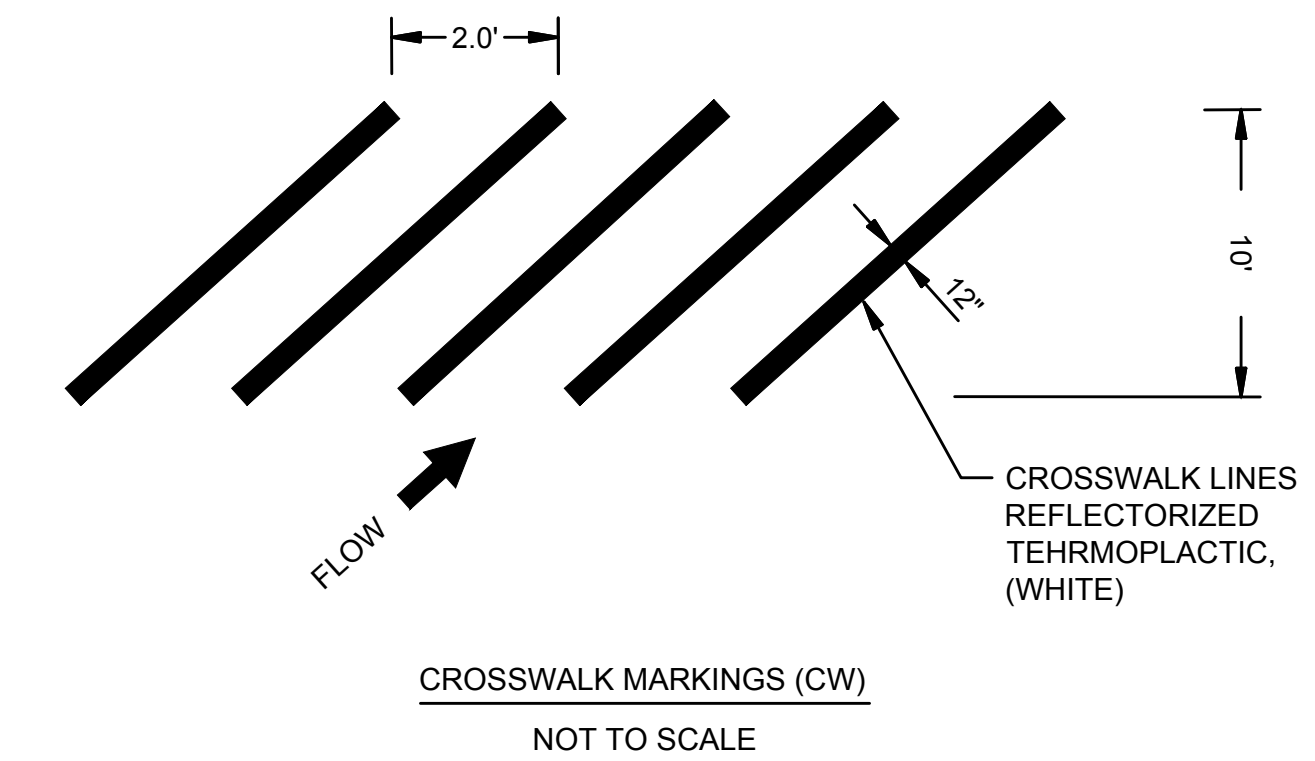
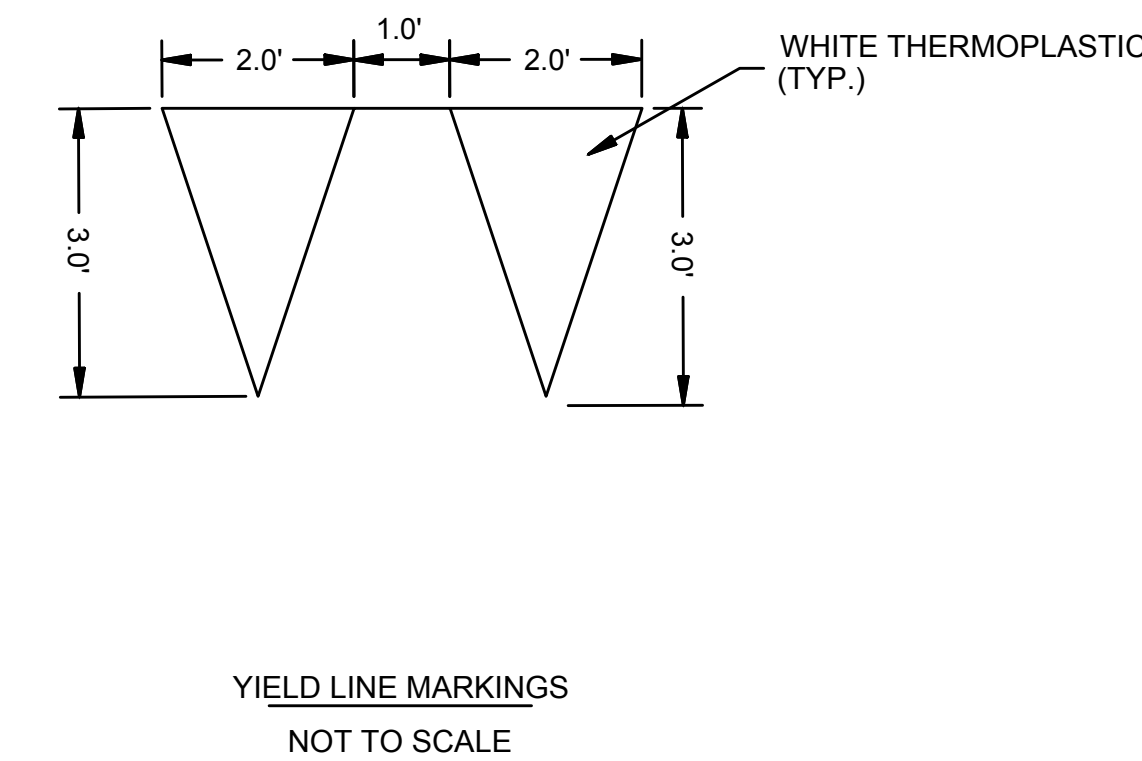
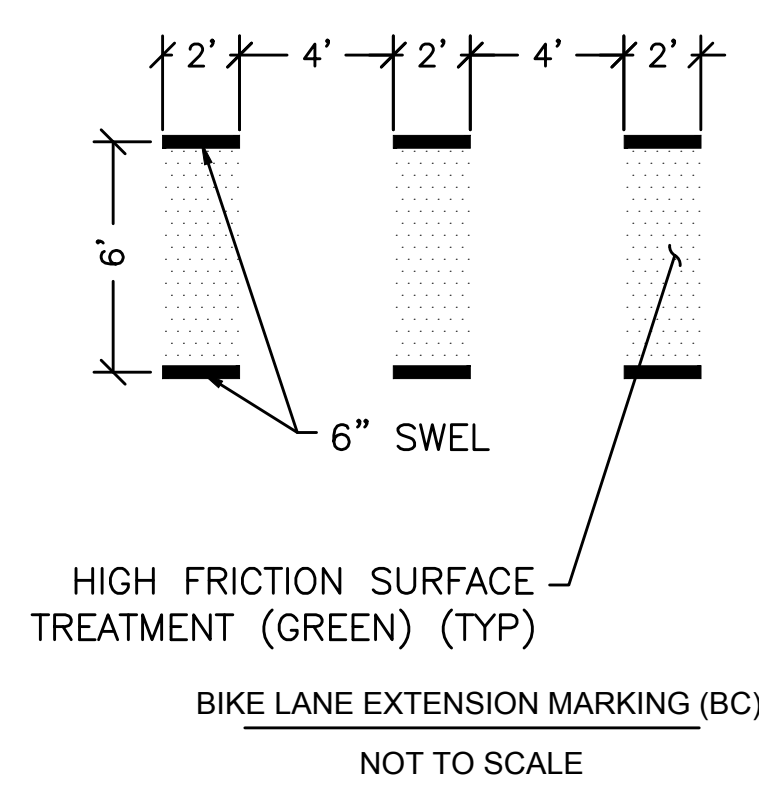
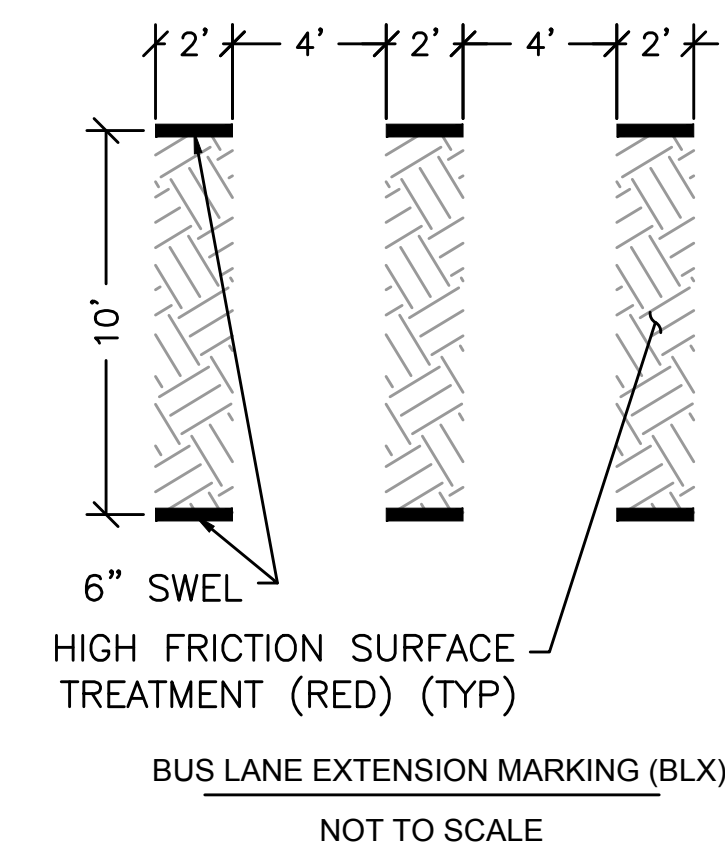

**ABBREVIATIONS**

APPROX.	APPROXIMATE	PED	PEDESTRIAN
AUX	AUXILIARY	PVMT	PAVEMENT
⊥	BASELINE	R	RADIUS OF CURVATURE
BLVD	BOULEVARD	RET	RETAIN
CB	CATCH BASIN	R&D	REMOVE & DISCARD
CC	CEMENT CONCRETE	R&R	REMOVE & RESET
CEN	CENTER	R&S	REMOVE & STACK
CI	CURB INLET	ROW	RIGHT OF WAY
CIP	CAST IRON PIPE	RP	REMOVE PANEL
⊥	CENTER LINE	RP&P	REPLACE POST & PANEL
CONC	CONCRETE	SB	SOUTHBOUND
EB	EASTBOUND	SHLD	SHOULDER
EL	ELEVATION	SW	SIDEWALK
EP	EDGE OF PAVEMENT	ST	STREET
EQ	EQUIDISTANT	TAN	TANGENT
EX	EXISTING	TEMP	TEMPORARY
GD	GROUND	TYP	TYPICAL
GRAN	GRANITE	VAR	VARIABLE
LO	LAYOUT	WB	WESTBOUND
LP	LIGHT POLE		
MED	MEDIAN		
MH	MANHOLE		
MNT	MOUNT		
NB	NORTHBOUND		
O.C.	ON CENTER		

**PAVEMENT MARKING LEGEND**

SWEL	6" SOLID WHITE EDGE LINE
SWLL	6" SOLID WHITE LANE LINE
SWBLL	8" SOLID WHITE BIKE LANE LINE
SWCHL	12" SOLID WHITE CHANNELIZATION LINE
SL	12" SOLID WHITE STOP LINE
SYCL	6" SOLID YELLOW CENTER LINE
DYCL	6" SOLID DOUBLE YELLOW CENTER LINE
BWLL	6" BROKEN WHITE LANE LINE 10' MARK - 30' SKIP
DWL	6" DOTTED WHITE LINE EXTENSION 2' MARK - 6' SKIP

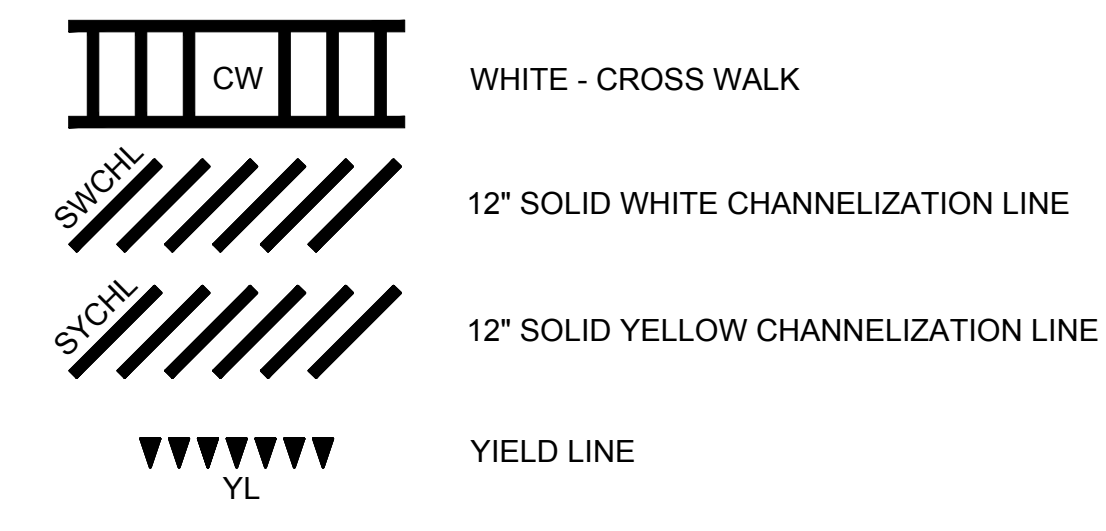

EXISTING	PROPOSED	DESCRIPTION
⊥	⊥	SIGN AND POST
⊥ ⊥	⊥ ⊥	SIGN AND POST (2 POSTS)
	⊥ BKE	BIKE LANE SYMBOL
	⊥ BKE	SHARED LANE MARKING SYMBOL
	⊥ ONLY	WHITE PAVEMENT LEGEND AND ARROW

SOMERVILLE CENTRAL BROADWAY			
STATE	FED. AID PROJ. NO.	SHEET NO.	TOTAL SHEETS
MA		3	13
PROJECT FILE NO.		XXXXXX	

TRAFFIC SIGNS & PAVEMENT MARKINGS

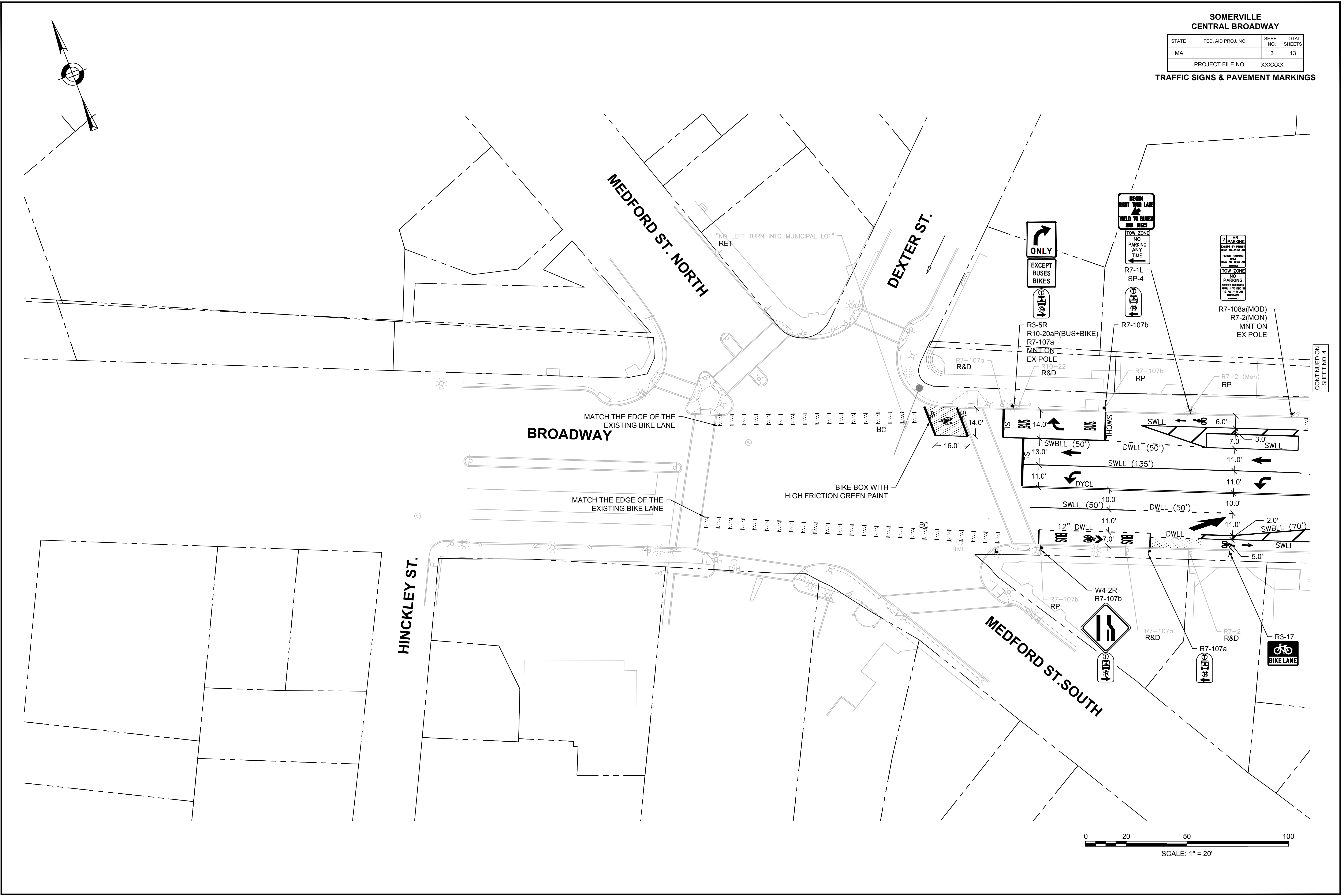

CONTINUED ON  
SHEET NO. 4

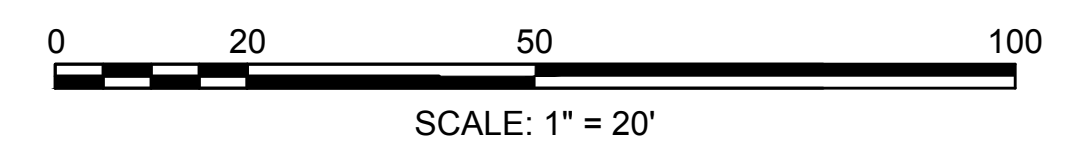

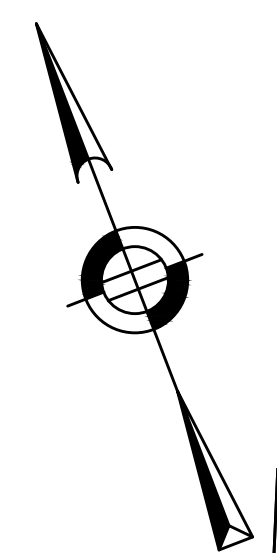

CONTINUED ON SHEET NO. 3

CONTINUED ON SHEET NO. 5

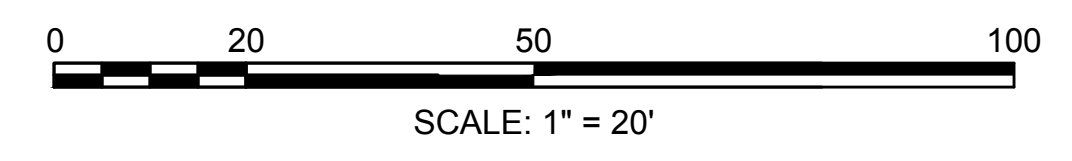

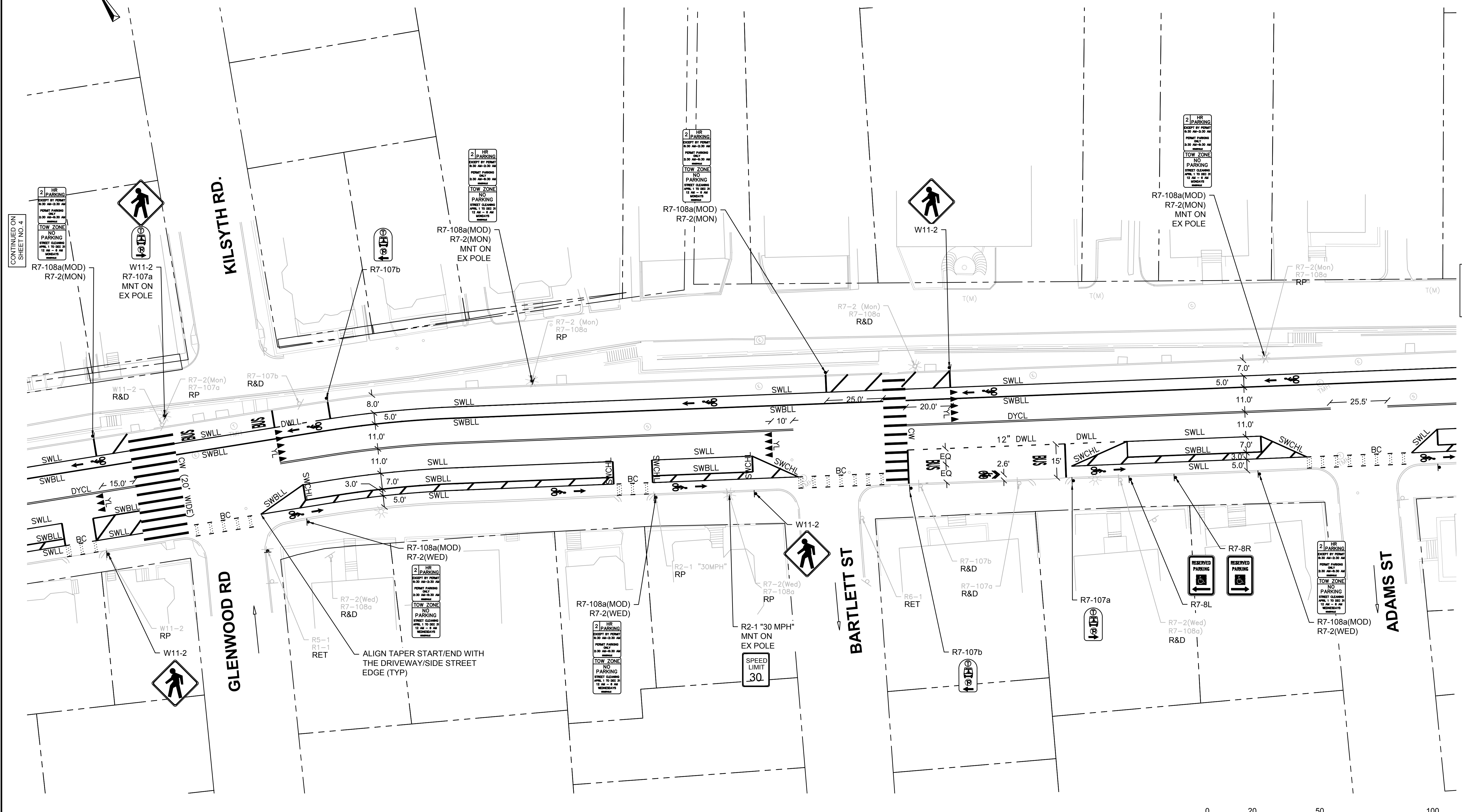
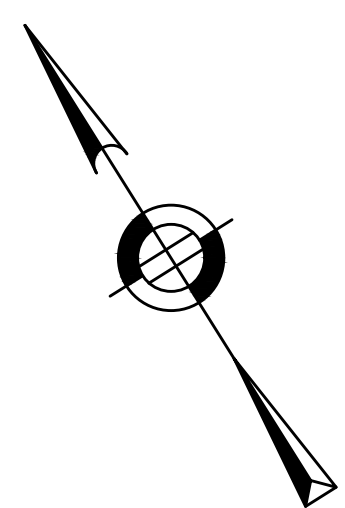

CONTINUED ON SHEET NO. 4

CONTINUED ON SHEET NO. 6

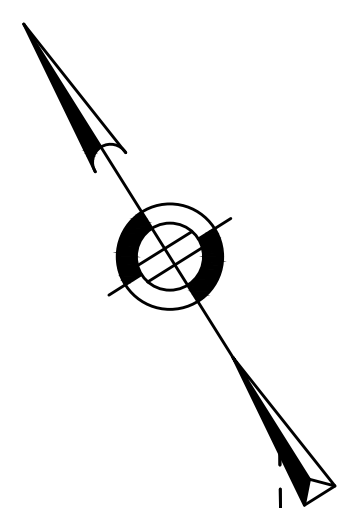

CONTINUED ON  
SHEET NO. 5

CONTINUED ON  
SHEET NO. 7

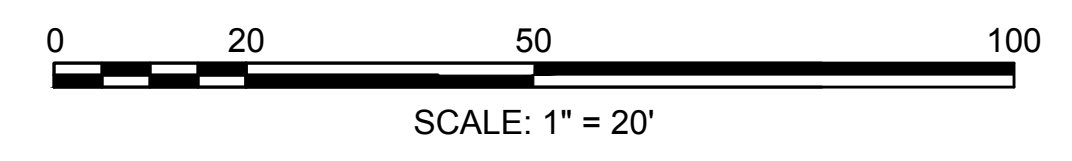
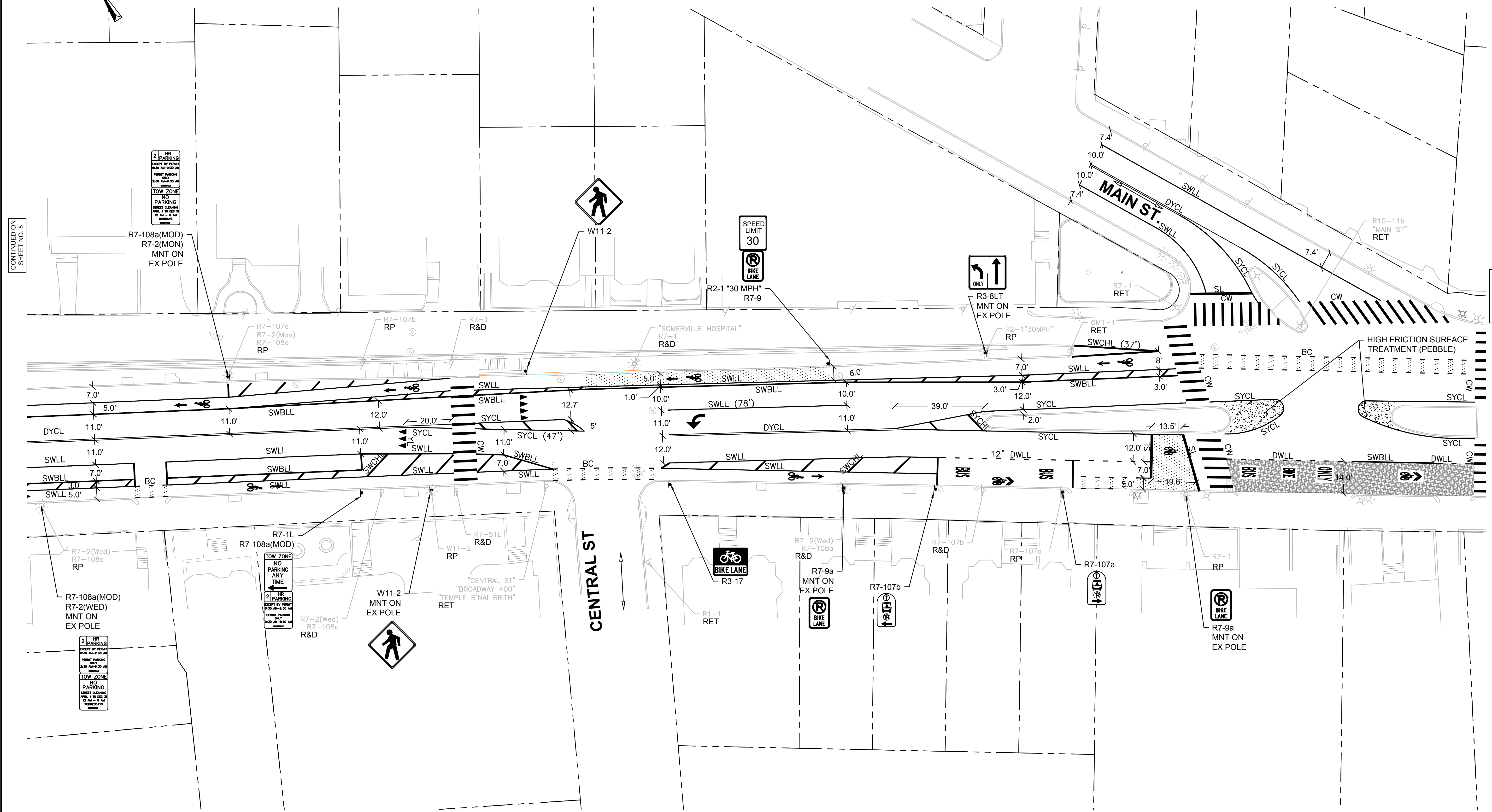

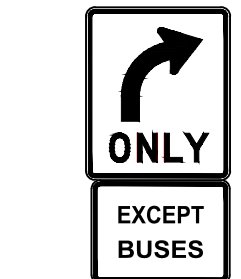
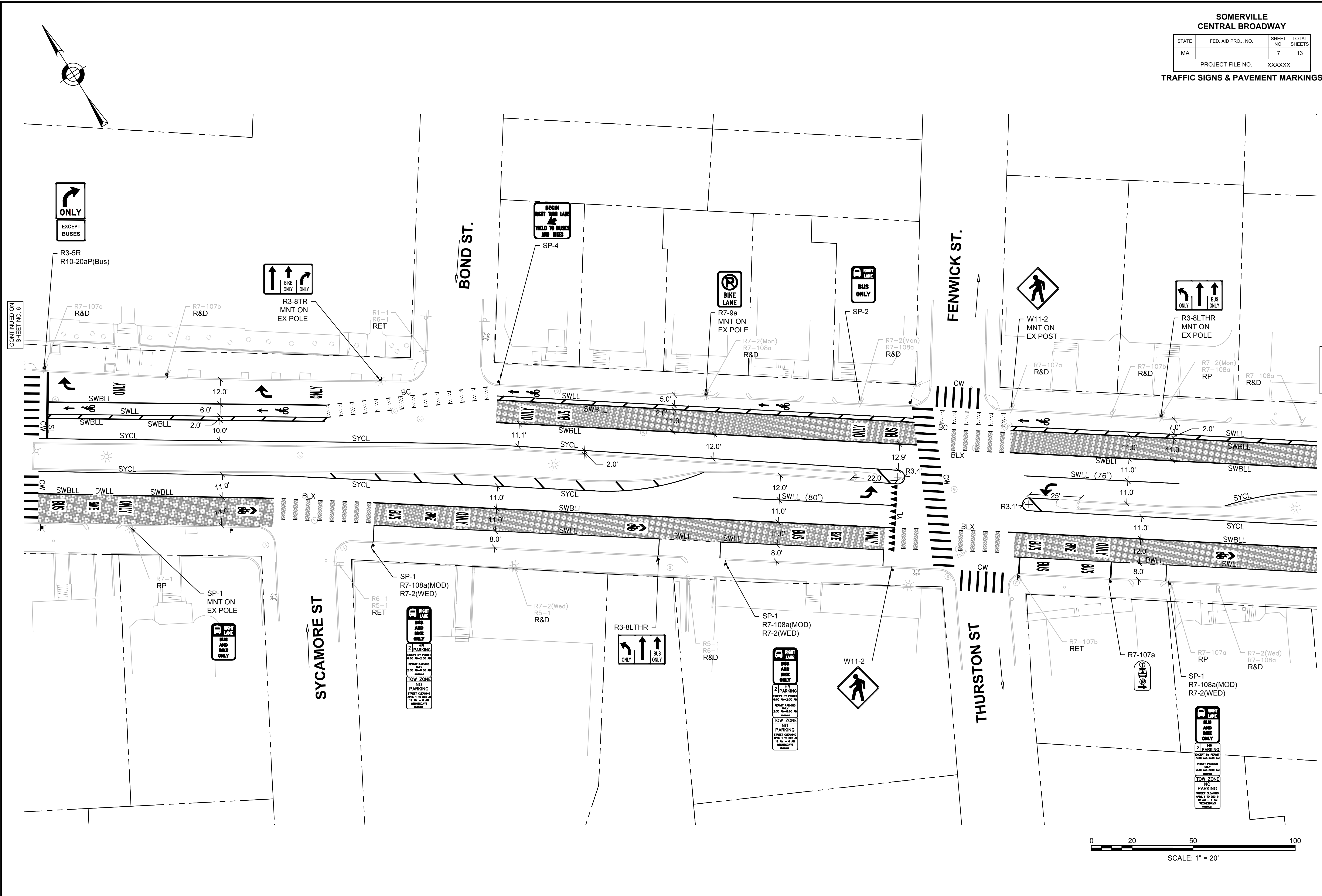

CONTINUED ON SHEET NO. 6

CONTINUED ON SHEET NO. 8

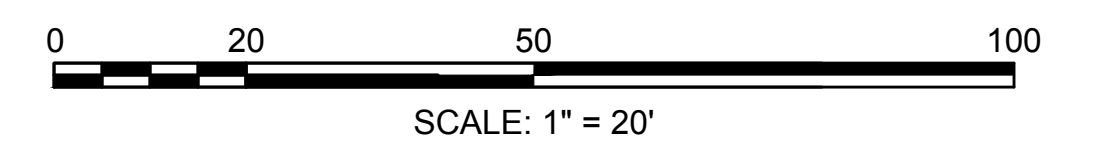

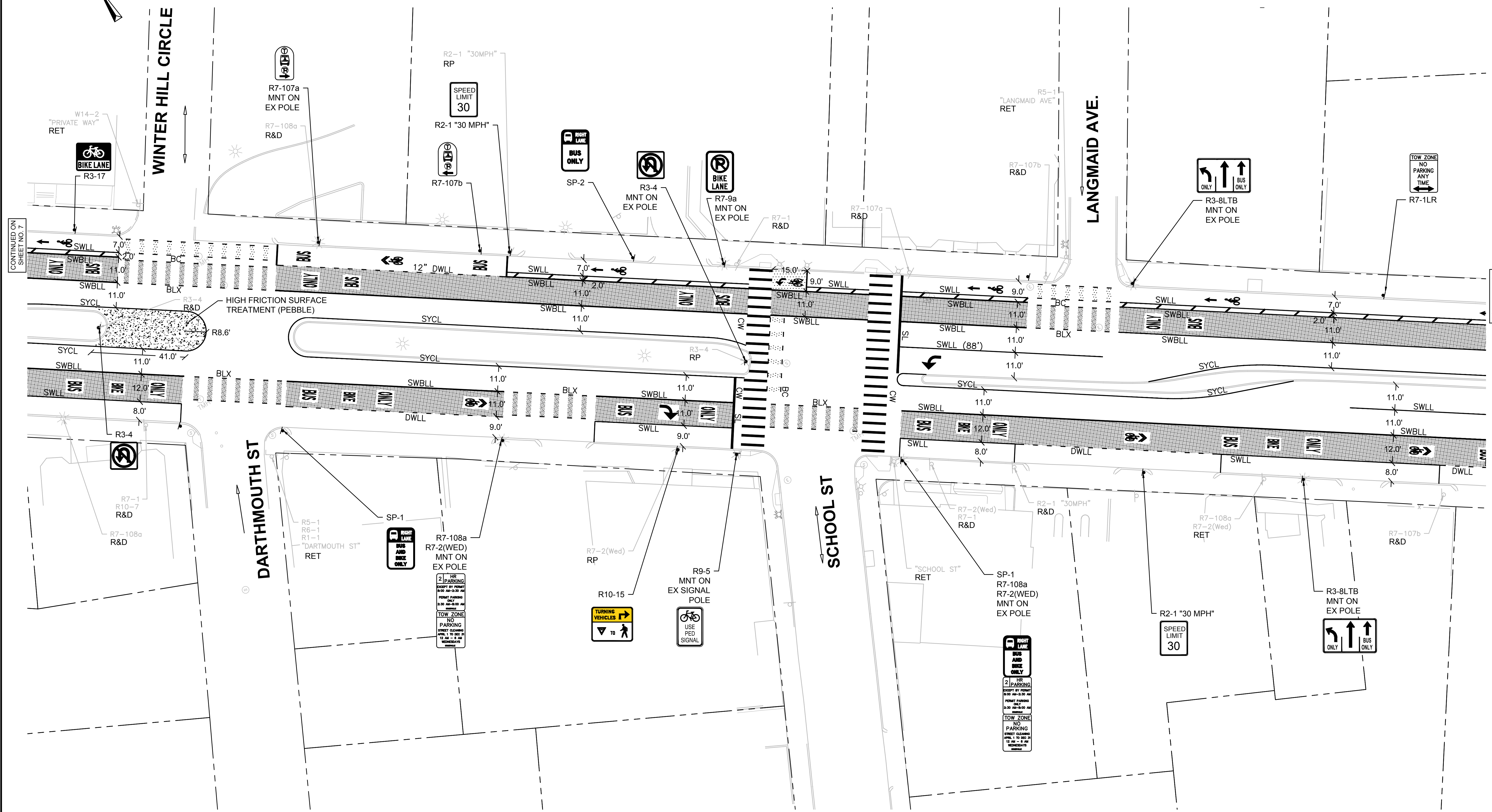
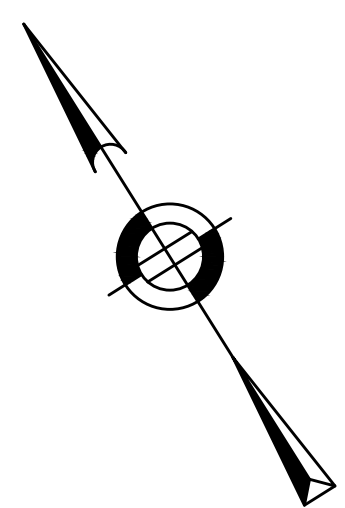

CONTINUED ON SHEET NO. 7

CONTINUED ON SHEET NO. 9

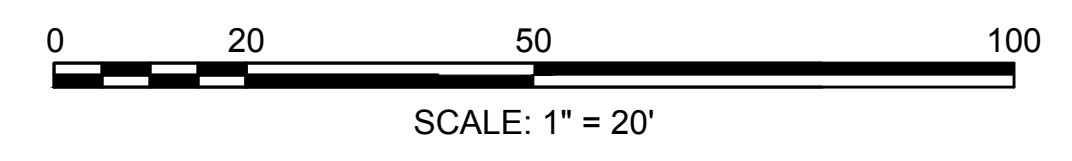



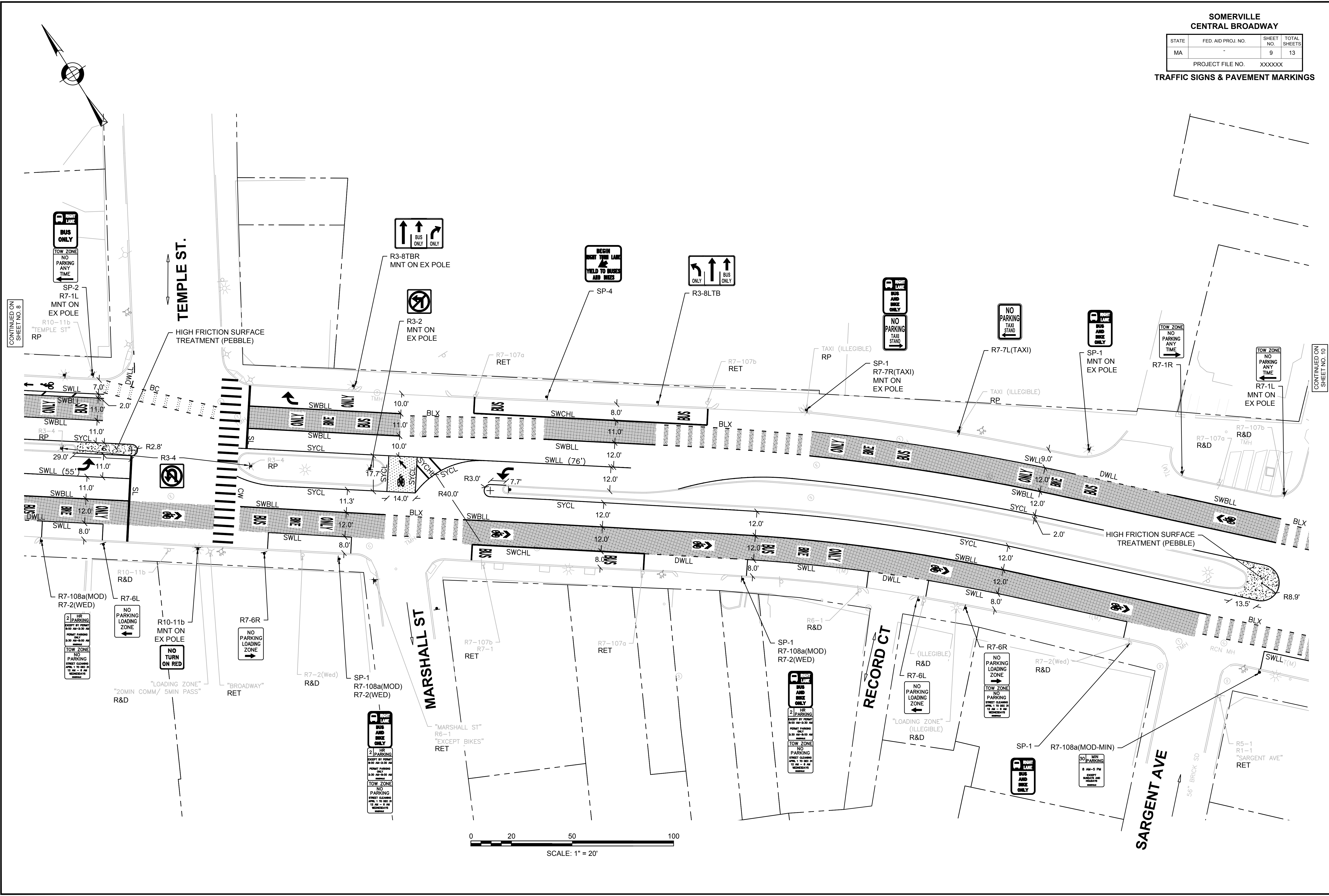

CONTINUED ON SHEET NO. 8

CONTINUED ON SHEET NO. 10

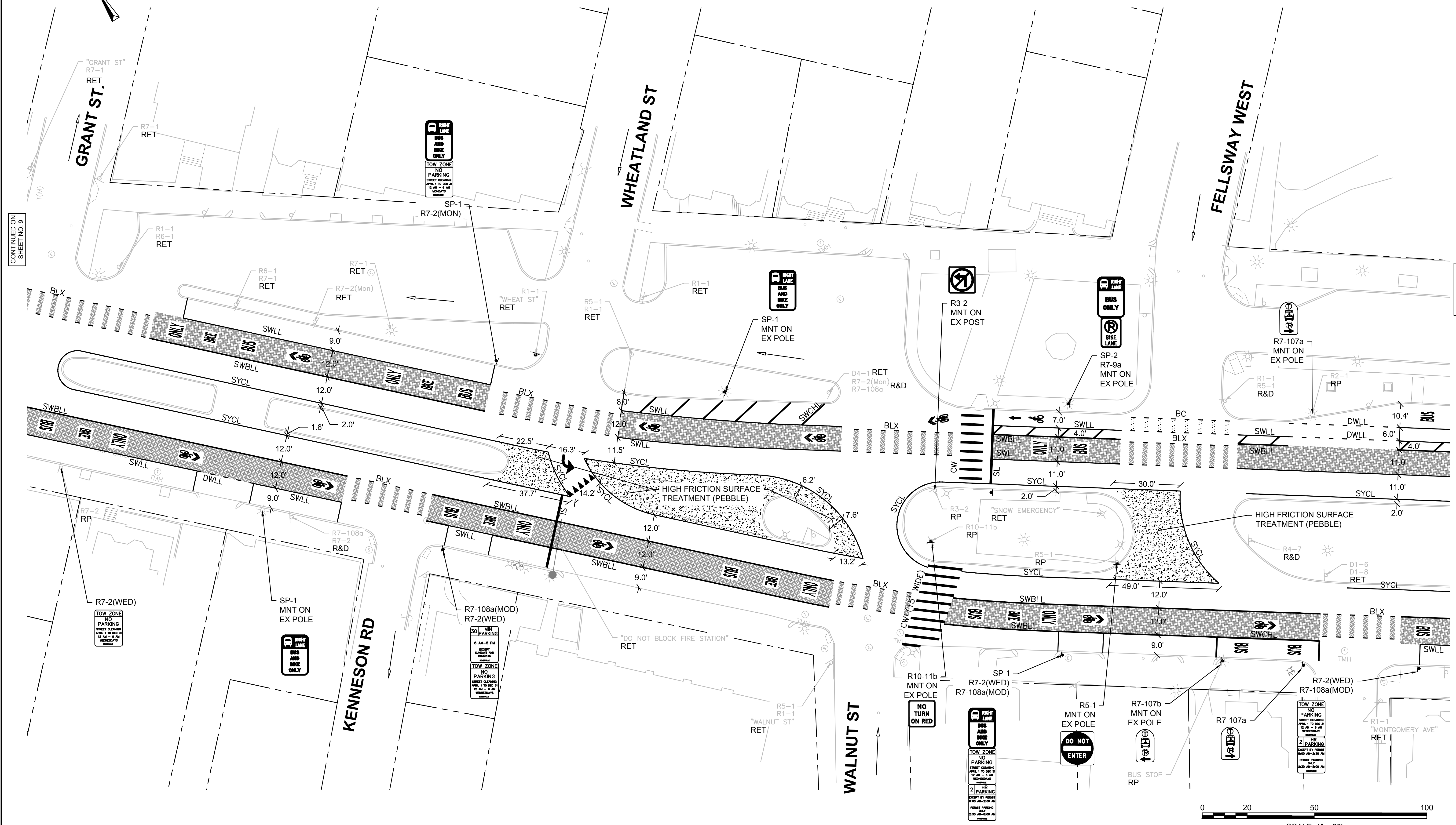
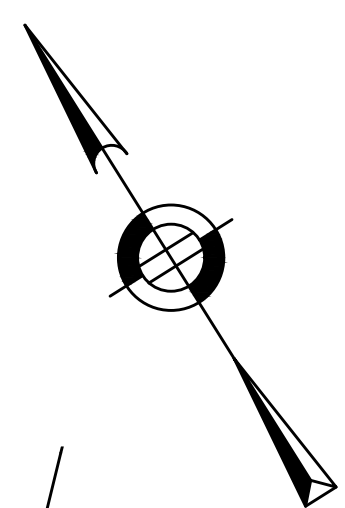

CONTINUED ON SHEET NO. 9

CONTINUED ON SHEET NO. 11

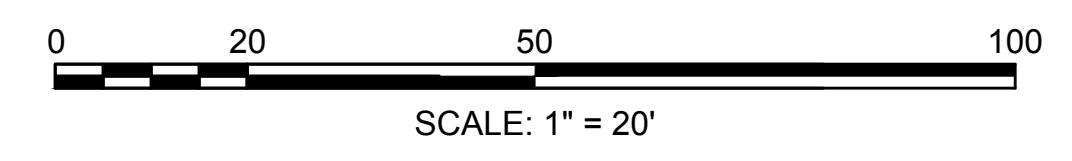

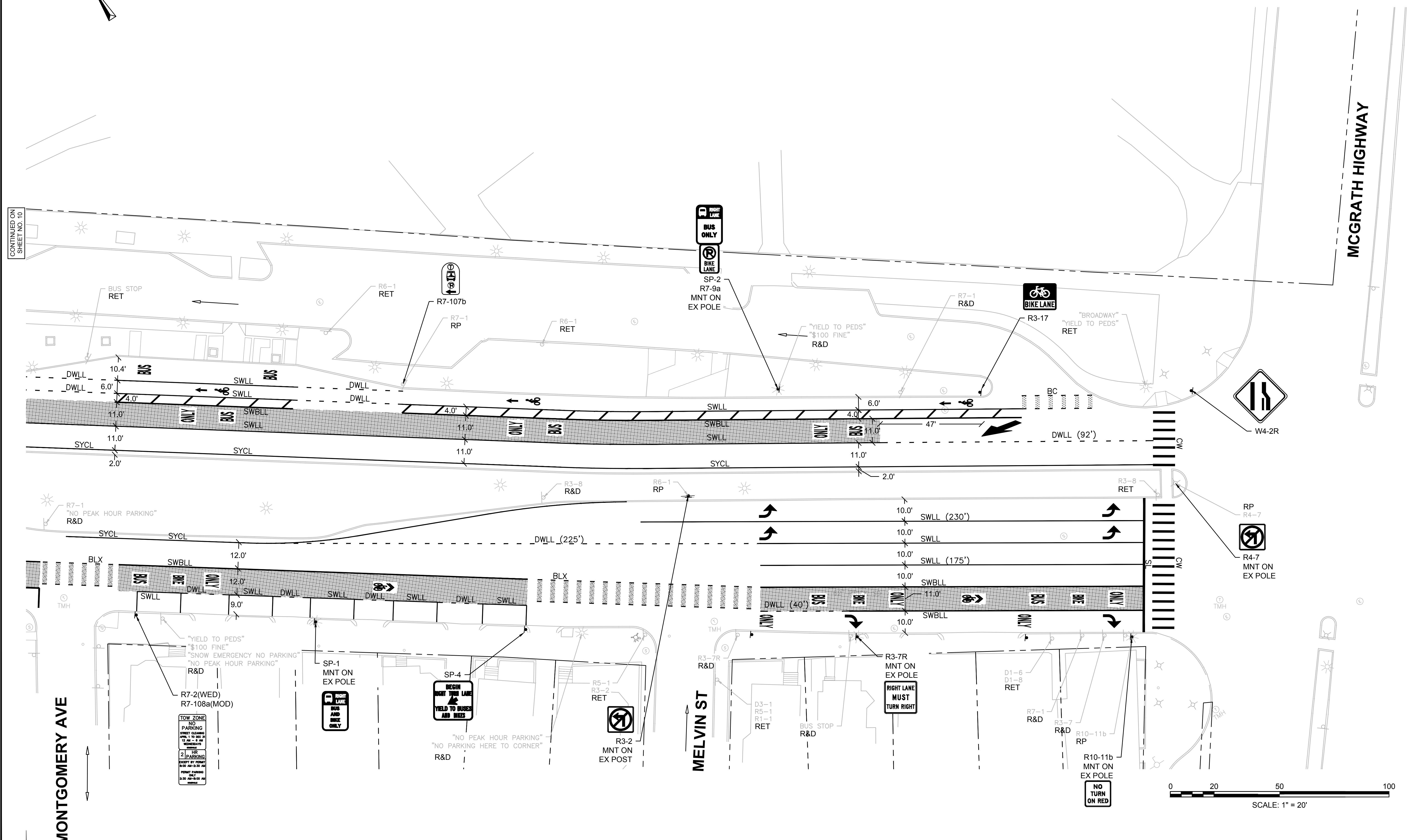
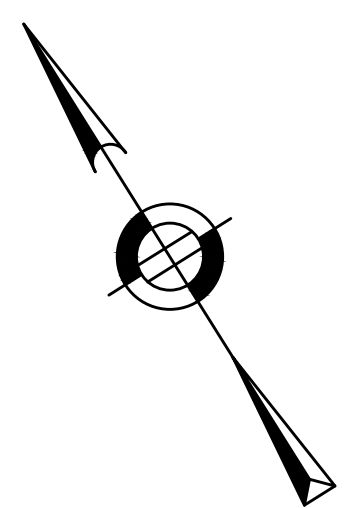

CONTINUED ON SHEET NO. 10

**MCGRATH HIGHWAY**

**MONTGOMERY AVE**

**MELVIN ST**

**TOW ZONE**  
NO PARKING  
STREET CLEARING  
APR. 1 TO DEC. 31  
12 AM - 6 AM  
MONDAYS ONLY

**2 HOUR PARKING**  
EXCEPT BY PERMIT  
8:00 AM - 5:30 PM

**BEGIN  
RIGHT TURN LANE  
YIELD TO BUSES  
AND BIKES**

**RIGHT LANE  
MUST  
TURN RIGHT**

**NO TURN  
ON RED**

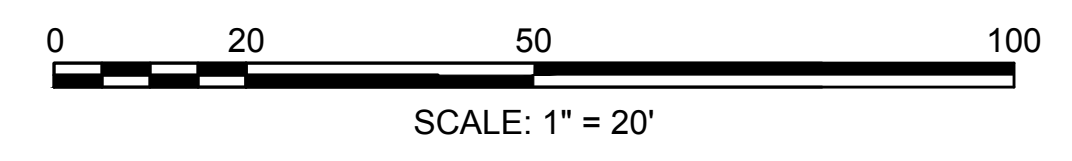

SOMERVILLE  
CENTRAL BROADWAY

STATE	FED. AID PROJ. NO.	SHEET NO.	TOTAL SHEETS
MA		12	13
PROJECT FILE NO.		XXXXXX	

SIGN SUMMARY AND SIGN DETAIL



IDENTIFICATION NUMBER	SIZE OF SIGN (INCHES)		UNIT AREA SF	TEXT	TEXT DIMENSIONS	NUMBER OF SIGNS REQUIRED	COLOR	POST SIZE AND NUMBER REQUIRED PER SIGN	AREA IN SQUARE FEET
	WIDTH	HEIGHT							
R2-1	24"	30"	5.00		SEE MUTCD STANDARD DETAIL	4	SEE MUTCD STANDARD DETAIL	MNT 2 ON EXIST POLES AND 2" POST (2)	20.00
R3-2	24"	24"	4.00			5		MNT 5 ON EXIST POST	20.00
R3-4	24"	24"	4.00			4		MNT 4 ON EXIST POST	16.00
R3-5R	30"	36"	7.50			2		MNT 2 ON EXIST POLE	15.00
R3-7R	30"	30"	6.25			1		MNT 1 ON EXIST POLE	6.25
R7-7L(TAXI)	12"	18"	1.50			1		MNT 1 ON EXIST POST	1.50
R7-7R(TAXI)	12"	18"	1.50			1		MNT 1 ON EXIST POLE	1.50
R3-8	VARIES	30"	VARIES			8		MNT 5 ON EXIST POLE AND 2" POST (3)	80.00
R3-17	30"	24"	5.00			5		MNT 1 ON EX POLE AND ON 2" POST (4)	25.00
R7-1L	12"	18"	1.50			4		MNT 2 ON EXIST POLE AND 2" POST (2)	6
R7-1R	12"	18"	1.50			2		MNT ON 2" POST (2)	3
R7-1LR	12"	18"	1.50			4		MNT 4 ON EXIST POLE	6.00
R7-2	12"	18"	1.50			29		MNT 8 ON EX POLE, 2 ON EX POST, 2" POST (19)	43.50
R10-15	30"	30"	6.25			1		MNT 1 ON 2" POST	6.25

IDENTIFICATION NUMBER	SIZE OF SIGN (INCHES)		UNIT AREA SF	TEXT	TEXT DIMENSIONS	NUMBER OF SIGNS REQUIRED	COLOR	POST SIZE AND NUMBER REQUIRED PER SIGN	AREA IN SQUARE FEET
	WIDTH	HEIGHT							
R7-6L	12"	18"	1.50		SEE MUTCD STANDARD DETAIL	2	SEE MUTCD STANDARD DETAIL	MNT ON 2" POST (2)	3.00
R7-6R	12"	18"	1.50			2		MNT ON 2" POST (2)	3.00
R7-8L	12"	18"	1.50			1		MNT ON 2" POST (1)	1.50
R7-8R	12"	18"	1.50			1		MNT ON 2" POST (1)	1.50
R7-9a	12"	18"	1.50			7		MNT 1 ON EXIST POLE AND 2 WITH R3-11b	10.5
R7-107a	12"	30"	2.50			14		MNT 6 ON EX POLE, 3 ON EX POST, 2" POST (5)	35.00
R7-107b	12"	30"	2.50			13		MNT 2 ON EX POLE, 6 ON EX POST, 2" POST (5)	32.50
R7-108a	12"	18"	1.50			28		MNT 27 WITH R7-2, 2" POST (1)	42.00
R9-5	12"	18"	1.50			1		MNT 1 ON EXIST POST	1.50
R10-11b	36"	36"	9.00			3		MNT 2 ON EX POLE AND 1 ON EX POST	27.00
R10-20aP(B)	24"	18"	3.00			2		MNT WITH R3-5R	6.00
R10-20aP	24"	18"	3.00			1		MNT WITH R3-2	3.00
R5-1	30"	30"	6.25			1		MNT 1 ON EXIST POST	6.25
W4-2R	30"	30"	6.25			2		MNT 1 ON EXIST POST AND 2" POST (1)	12.50
W11-2	24"	24"	4.00			8		MNT 2 ON EX POLE, 3 ON EX POST, 2" POST (3)	32.00

SOMERVILLE  
CENTRAL BROADWAY

STATE	FED. AID PROJ. NO.	SHEET NO.	TOTAL SHEETS
MA		13	13
PROJECT FILE NO.		XXXXXX	

SIGN SUMMARY AND SIGN DETAIL

IDENTIFICATION NUMBER	SIZE OF SIGN (INCHES)		UNIT AREA SF	TEXT	TEXT DIMENSIONS	NUMBER OF SIGNS REQUIRED	COLOR	POST SIZE AND NUMBER REQUIRED PER SIGN	AREA IN SQUARE FEET
	WIDTH	HEIGHT							
SP-1	24"	36"	6.00		SEE DETAIL	16	SEE MUTCD STANDARD DETAIL	MNT 7 ON EXIST POLES AND 2" POST (9)	96.00
SP-2	24"	36"	6.00			5		MNT 3 ON EXIST POLES AND 2" POST (3)	30.00
SP-4	36"	36"	9.00			4		MNT 4 ON EXIST POST	36.00



SP-1 SIGN DETAIL  
NOT TO SCALE

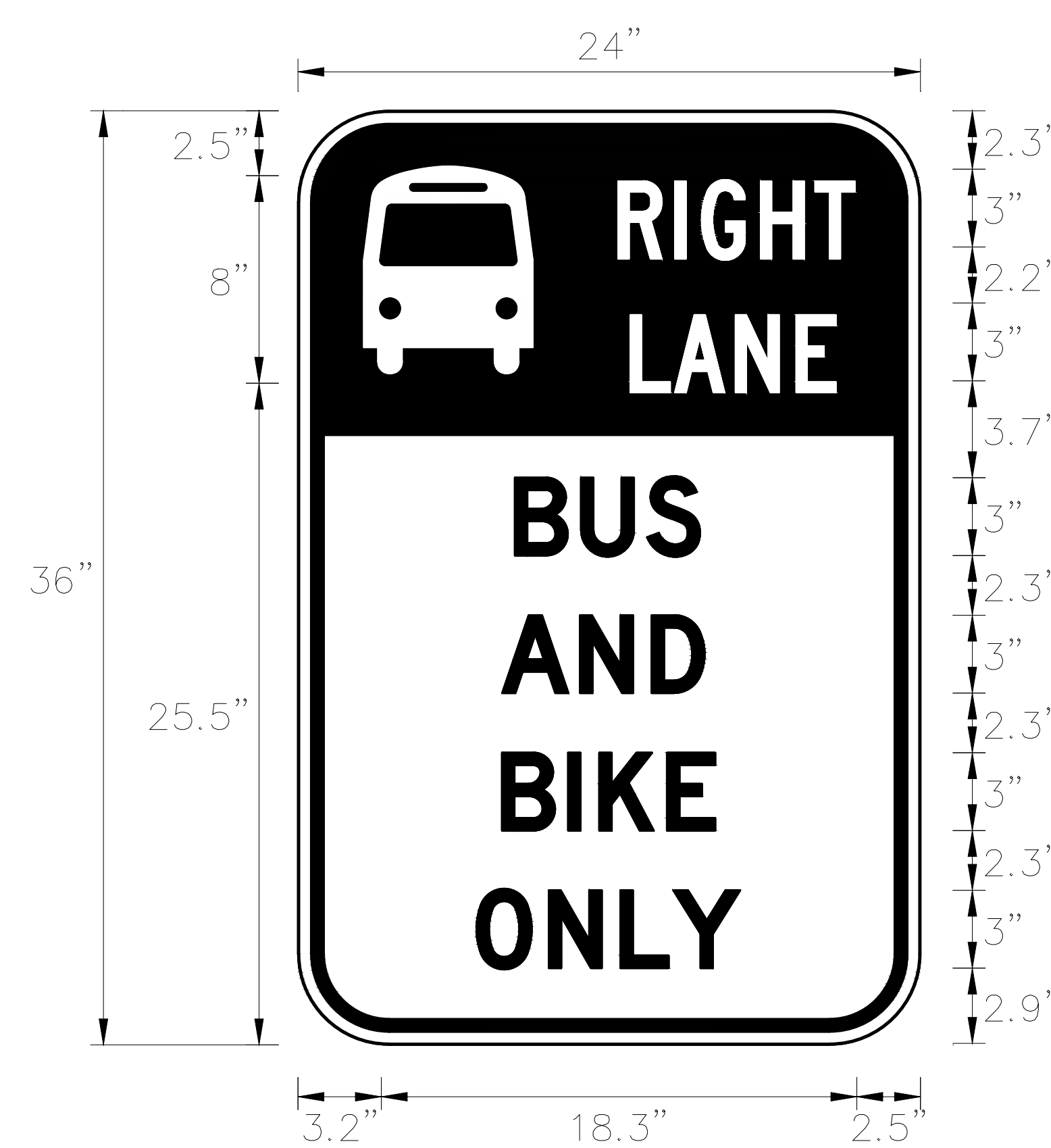

SP-2 SIGN DETAIL  
NOT TO SCALE

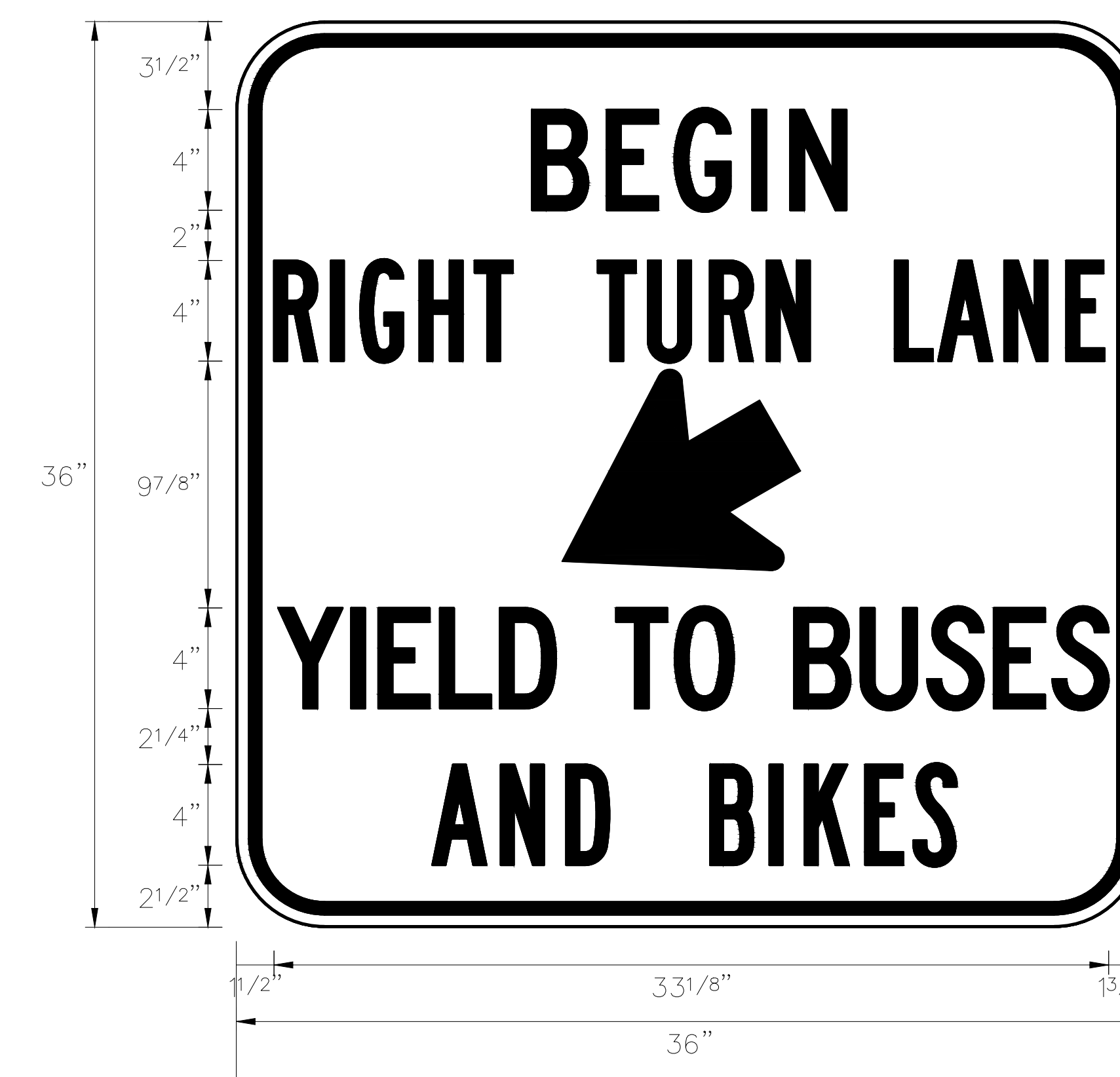

SP-4 SIGN DETAIL  
NOT TO SCALE